

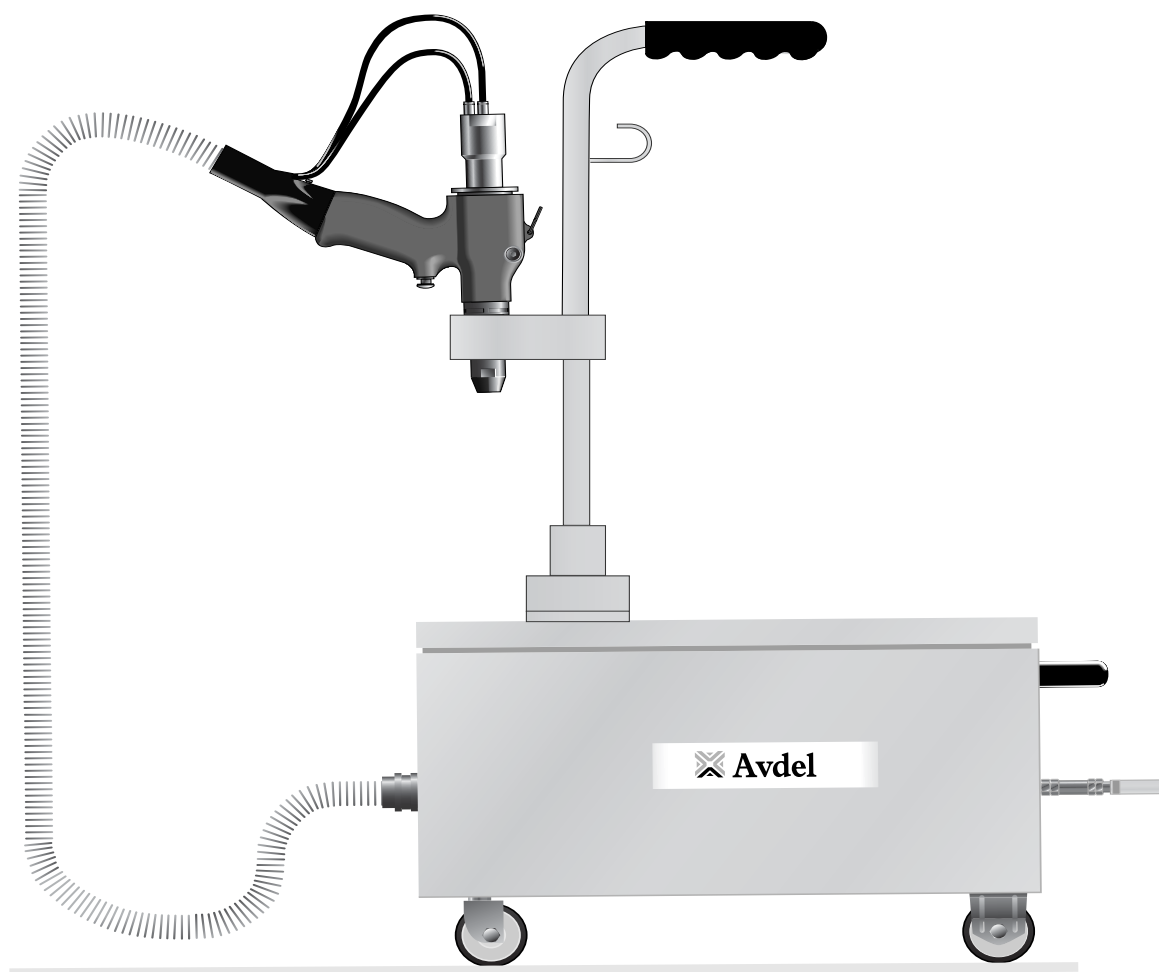

# Instruction Manual

Original Instruction



**74401**

**Threaded Insert Power Tool**

Avdel UK Limited policy is one of continuous development. Specifications shown in this document may be subject to changes which may be introduced after publication. For the latest information always consult Avdel.

### SPECIFICATIONS FOR THE 74401 TOOL

AIR PRESSURE	■	Minimum - Maximum	■	4 - 7 bar	■	60 - 100 lbf/in <sup>2</sup>
FREE AIR VOLUME REQUIRED	■	@ 5 bar or 75 lbf/in <sup>2</sup>	■	15 litres	■	.525 ft <sup>3</sup>
STROKE	■	Maximum	■	12 mm	■	.47 in
MOTOR SPEED	■	SPIN ON	■	2500 RPM	■	
		SPIN OFF	■	3000 RPM	■	
PULL FORCE	■	@ 5 bar or 75 lbf/in <sup>2</sup>	■	35.93 kN	■	8077 lbf
CYCLE TIME	■	Approximately	■	3 seconds	■	
NOISE LEVEL	■	Less than	■	70 dB(A)	■	
WEIGHT	■	w/o nose equipment or hose	■	2 kg	■	4.4 lb
VIBRATION	■	Less than	■	2.5 m/s <sup>2</sup>	■	

### SPECIFICATIONS FOR THE 74401 INTENSIFIER

AIR PRESSURE	■	Minimum - Maximum	■	4 - 7 bar	■	60 - 100 lbf/in <sup>2</sup>
INTENSIFICATION RATIO	■	51:1	■		■	

## SAFETY

General	2
Specific to Type of Tool	3

## INTENT OF USE

General	4
Tool Dimensions	4

## PUTTING INTO SERVICE

Air Supply	5
Stroke Adjustment	5
Operating Procedure	6
Connecting the Foot Pedal	7

## NOSE ASSEMBLIES

Fitting	8
Servicing	8
Components	9

## SERVICING

Regular Servicing	10
Service Kit	10
Maintenance	11-13
General Assembly & Parts List	14-20

## PRIMING

Priming Oil Details	22
Priming Procedure	22

## FAULT DIAGNOSIS

Fault Diagnosis Table	23
-----------------------	----

# S SAFETY

This instruction manual must be read with particular attention to the following safety rules, by any person installing, operating, or servicing this tool.

⚠ DO NOT USE OUTSIDE THE DESIGN INTENT.

⚠ DO NOT USE EQUIPMENT WITH THIS TOOL/MACHINE OTHER THAN THAT RECOMMENDED AND SUPPLIED BY AVDEL.

⚠ ANY MODIFICATION UNDERTAKEN BY THE CUSTOMER TO THE TOOL/MACHINE, NOSE ASSEMBLIES, ACCESSORIES OR ANY EQUIPMENT SUPPLIED BY AVDEL OR THEIR REPRESENTATIVES, SHALL BE THE CUSTOMER'S ENTIRE RESPONSIBILITY. AVDEL WILL BE PLEASED TO ADVISE UPON ANY PROPOSED MODIFICATION.

⚠ THE TOOL/MACHINE MUST BE MAINTAINED IN A SAFE WORKING CONDITION AT ALL TIMES AND EXAMINED AT REGULAR INTERVALS FOR DAMAGE AND FUNCTION BY TRAINED COMPETENT PERSONNEL. ANY DISMANTLING PROCEDURE SHALL BE UNDERTAKEN ONLY BY PERSONNEL TRAINED IN AVDEL PROCEDURES. DO NOT DISMANTLE THIS TOOL/MACHINE WITHOUT PRIOR REFERENCE TO THE MAINTENANCE INSTRUCTIONS. CONTACT AVDEL WITH YOUR TRAINING REQUIREMENTS.

⚠ THE TOOL/MACHINE SHALL AT ALL TIMES BE OPERATED IN ACCORDANCE WITH RELEVANT HEALTH AND SAFETY LEGISLATION. IN THE U.K. THE "HEALTH AND SAFETY AT WORK ETC. ACT 1974" APPLIES. ANY QUESTION REGARDING THE CORRECT OPERATION OF THE TOOL/MACHINE AND OPERATOR SAFETY SHOULD BE DIRECTED TO AVDEL.

⚠ THE PRECAUTIONS TO BE OBSERVED WHEN USING THIS TOOL/MACHINE MUST BE EXPLAINED BY THE CUSTOMER TO ALL OPERATORS.

⚠ ALWAYS DISCONNECT THE AIRLINE FROM THE TOOL/MACHINE INLET BEFORE ATTEMPTING TO ADJUST, FIT OR REMOVE A NOSE ASSEMBLY.

⚠ DO NOT OPERATE A TOOL/MACHINE THAT IS DIRECTED TOWARDS ANY PERSON(S).

⚠ ALWAYS ADOPT A FIRM FOOTING OR A STABLE POSITION BEFORE OPERATING THE TOOL/MACHINE.

⚠ ENSURE THAT VENT HOLES DO NOT BECOME BLOCKED OR COVERED AND THAT HOSES ARE ALWAYS IN GOOD CONDITION.

---

In addition to the general safety rules opposite, the following specific safety points must also be observed:

⚠ THE OPERATING PRESSURE SHALL NOT EXCEED 7 BAR - 100 LBF/IN<sup>2</sup>.

⚠ DO NOT OPERATE THE TOOL WITHOUT FULL NOSE EQUIPMENT, OIL PLUG AND OIL BLEED SCREW IN PLACE.

⚠ WHEN USING THE TOOL, THE WEARING OF SAFETY GLASSES IS REQUIRED BOTH BY THE OPERATOR AND OTHERS IN THE VICINITY TO PROTECT AGAINST FASTENER PROJECTION, SHOULD A FASTENER BE PLACED 'IN AIR'. WE RECOMMEND WEARING GLOVES IF THERE ARE SHARP EDGES OR CORNERS ON THE APPLICATION.

⚠ TAKE CARE TO AVOID ENTANGLEMENT OF LOOSE CLOTHES, TIES, LONG HAIR, CLEANING RAGS ETC... IN THE MOVING PARTS OF THE TOOL WHICH SHOULD BE KEPT DRY AND CLEAN FOR BEST POSSIBLE GRIP.

⚠ WHEN CARRYING THE TOOL FROM PLACE TO PLACE KEEP HANDS AWAY FROM THE TRIGGER/LEVER AND EMERGENCY SPIN-OFF BUTTON TO AVOID INADVERTENT START UP.

⚠ EXCESSIVE CONTACT WITH HYDRAULIC OIL SHOULD BE AVOIDED. TO MINIMIZE THE POSSIBILITY OF RASHES, CARE SHOULD BE TAKEN TO WASH THOROUGHLY.

# CONTENT OF USE

The hydro-pneumatic 74401 tool is designed to place Avdel threaded inserts at high speed making it ideal for batch or flow-line assembly in a wide variety of applications throughout all industries.

Use the selection chart page 7 to select a complete tool.

It is also possible to order the handle with no hoses, part number 74401-12000, or the cabinet only, part number 07265-03201.

Other items include :	74401-01000	Basic tool with 5m hose assembly
	74401-13500	Hose assembly (5m)
	74401-13900	Complete cabinet without intensifier
	74401-13000	Complete cabinet with intensifier

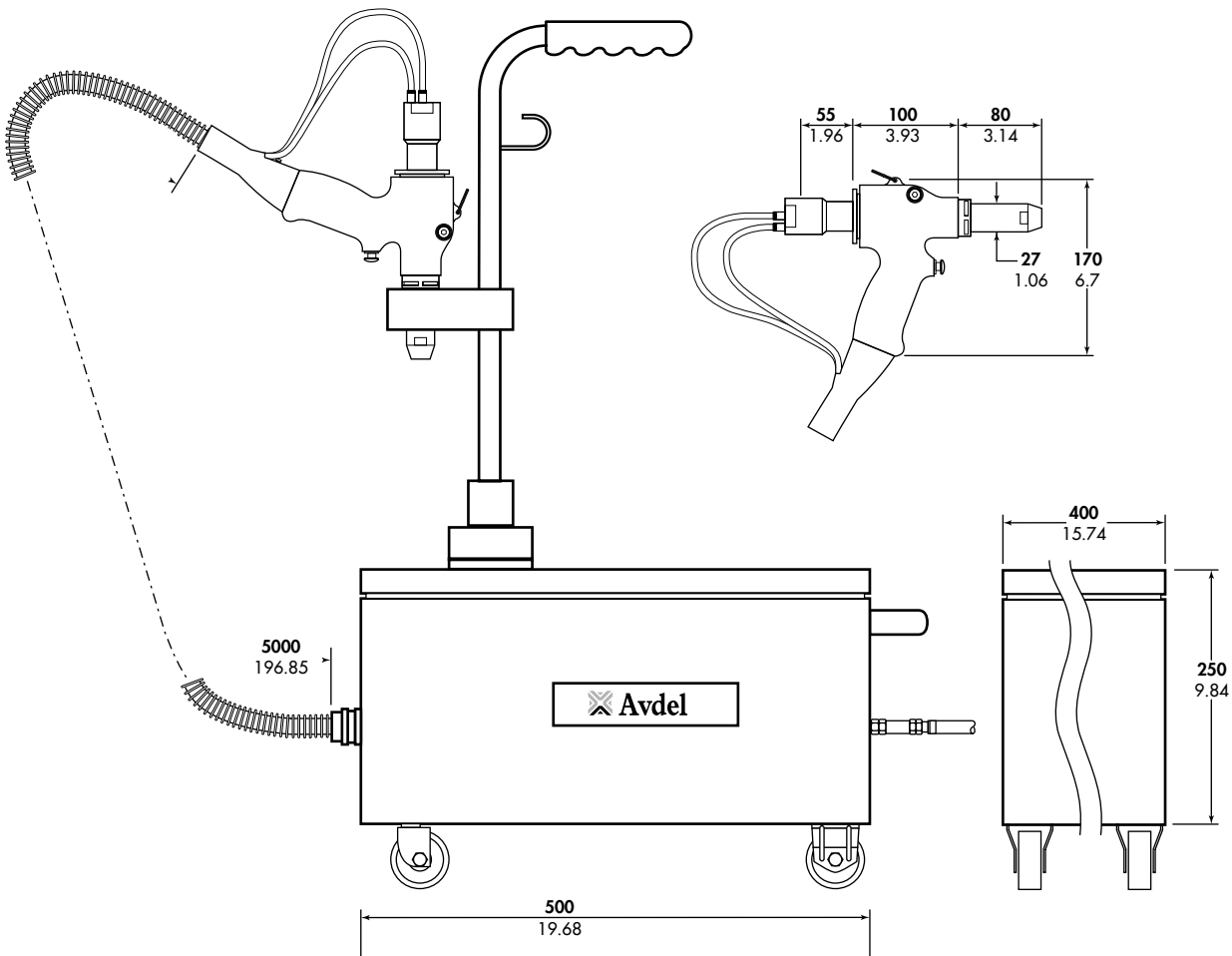

*Dimensions shown in bold are millimetres. Other dimensions are in inches.*

## AIR SUPPLY

All tools are operated with compressed air at an optimum pressure of 5.5 bar. We recommend the use of pressure regulators and automatic oiling/filtering systems on the main air supply. These should be fitted within 3 metres of the tool (see diagram below) to ensure maximum tool life and minimum tool maintenance.

Air supply hoses should have a minimum working effective pressure rating of 150% of the maximum pressure produced in the system or 10 bar, whichever is the highest. Air hoses should be oil resistant, have an abrasion resistant exterior and should be armoured where operating conditions may result in hoses being damaged. All air hoses MUST have a minimum bore diameter of 6.4 mm or 1/4 inch.

Read servicing daily details page 10.

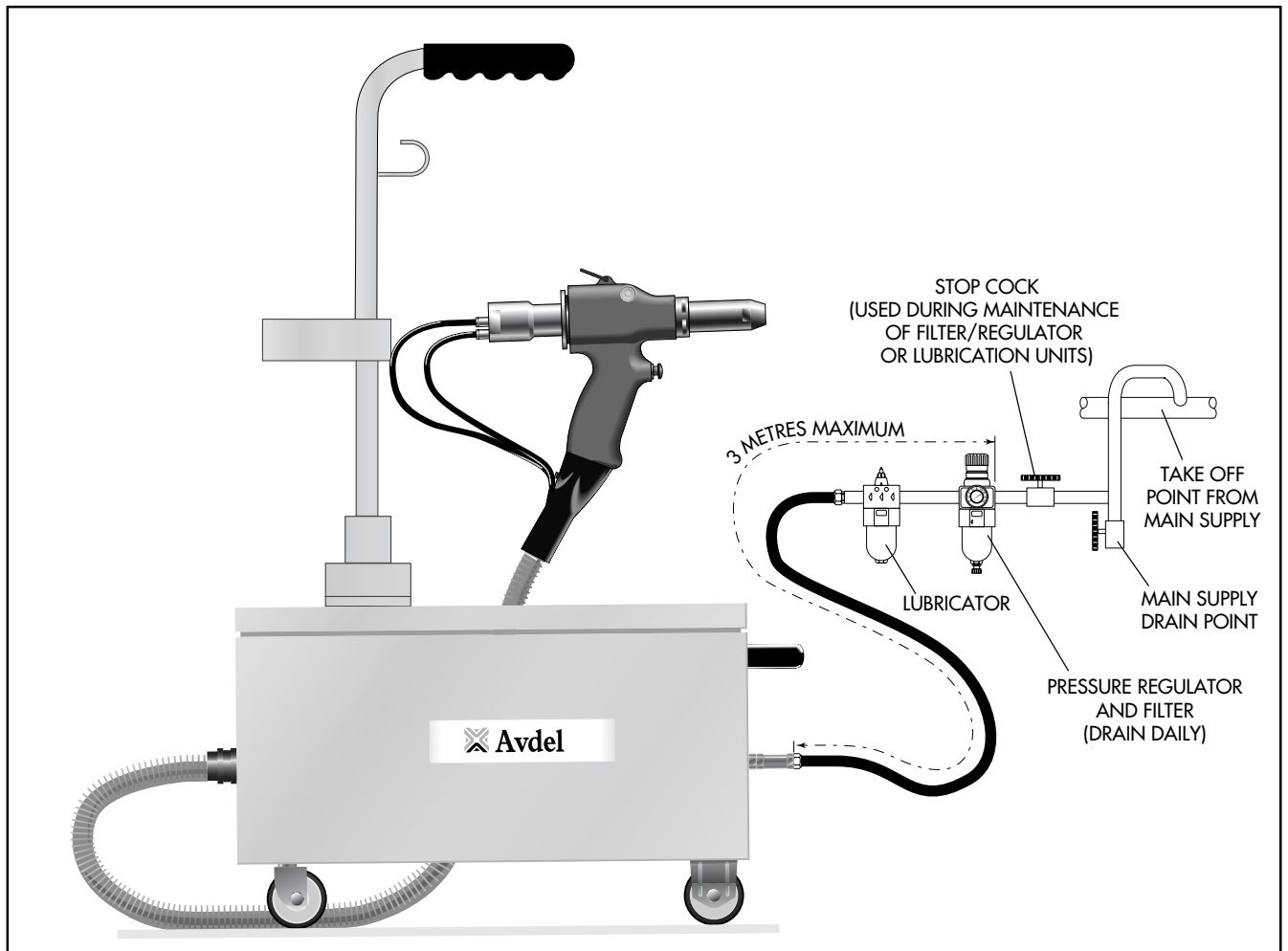

## STROKE ADJUSTMENT

This adjustment is necessary to ensure optimum insert deformation. It is suggested, therefore, that a test plate with the same thickness and hole size as workpiece be used.

If deformation is insufficient, the insert will rotate inside the application.

If deformation is excessive, thread distortion will occur and possibly drive screw fracture.

The stroke is adjusted by the amount the stroke adjustment locknut 12, (parts list page 15), is screwed in or out. To shorten stroke, screw in; to lengthen stroke, unscrew the rear casing. Adjust until optimum deformation is obtained.

## OPERATING PROCEDURE

- Connect tool to air supply.
- Offer up insert, lip first to drive screw. A light pressure will start the motor and automatically thread the insert up against nose and stop.
- Insert fastener into application squarely.
- Fully depress trigger. This will both place insert into the application and reverse it off the drive screw.

## ACCESSORIES

Two different accessories are available :

### COMBINED HANDLE & HOLSTER

Refer to the illustration opposite for details.

- Using the base 6 as a guide, spot through and drill four 5.5mm diameter holes in the position required on the cabinet lid.
- Place plate 12 on the inside of the cabinet lid.
- Place base 6 on the outside of the cabinet and using screws 7, screw the base / cabinet lid / and plate in position.
- Insert tube with hook 2 into the holster 4 and secure the holster 4 in position by tightening bolt 3 into nut 5.
- Insert tube and holster into base 6 and lock into position by tightening bolt 8 into bolt 5.
- Drill two 5.5mm holes, one at either end of the cabinet lid and secure clips 10 in position with 5mm bolts 9.

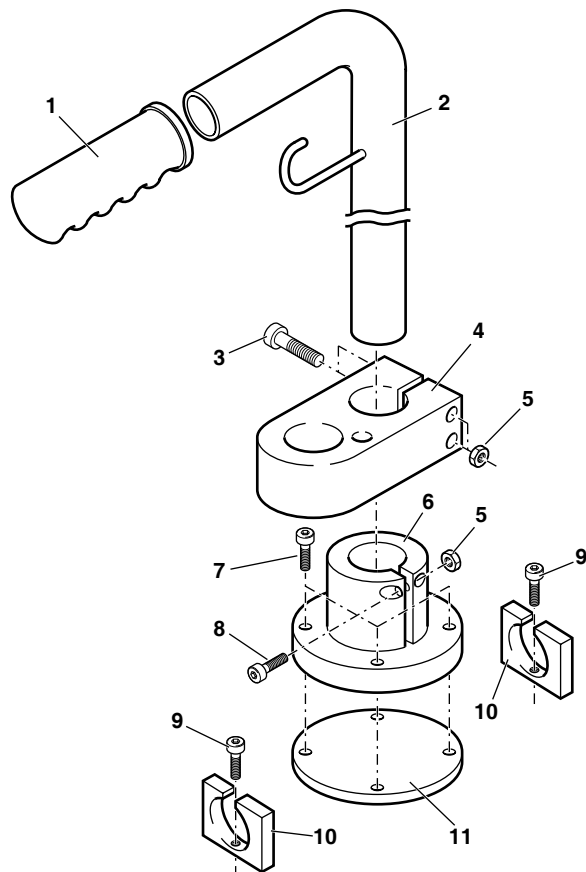

### 07265-09500 PARTS LIST

ITEM	PART N°	DESCRIPTION	QTY	SPARES
1	07265-09501	RUBBER HANDLE	1	-
2	07265-09502	TUBE WITH HOOK	1	-
3	07265-09504	M5 BOLTS	2	-
4	07265-09503	HOLSTER	1	-
5	07265-09505	M5 NUTS	3	-
6	07265-09508	BASE	1	-
7	07265-09507	M5 BOLT	4	-
8	07265-09506	M5 BOLT	1	-
9	07265-09512	M5 BOLT	2	-
10	07265-09511	CLIPS	2	-
11	07265-09509	PLATE	1	-

## CONNECTING THE FOOT PEDAL

- Please refer to the illustration for details.
- Disconnect the tool from the air supply.
- Open base **53**.
- Identify valve **27** connected to the air pressure regulator **48** (point F on GA, page 16).
- Disconnect the 4mm output hose which feeds the tool trigger (hose **68**, page 18).
- Connect 4mm air hose **4** to valve **27**.
- Connect the Y connector to air hose **4**.
- To one side of the Y connector, connect the hose from the tool trigger.
- To the other side of the Y connector, connect air hose **2**.
- Connect air hose **2** to the foot pedal.
- Close base **53** and reconnect air supply.
- Tool can now be operated with the foot pedal or the trigger and the emergency spin-off button **44** is still operable.

74401-13800 PARTS LIST				
ITEM	PART N°	DESCRIPTION	QTY	SPARES
1	07005-00077	FOOT PEDAL	1	-
2	74401-13801	4mm AIR HOSE (1000mm)	1	-
3	74401-13027	'Y' CONNECTOR	1	-
4	74401-13095	4mm AIR HOSE (250mm)	1	-

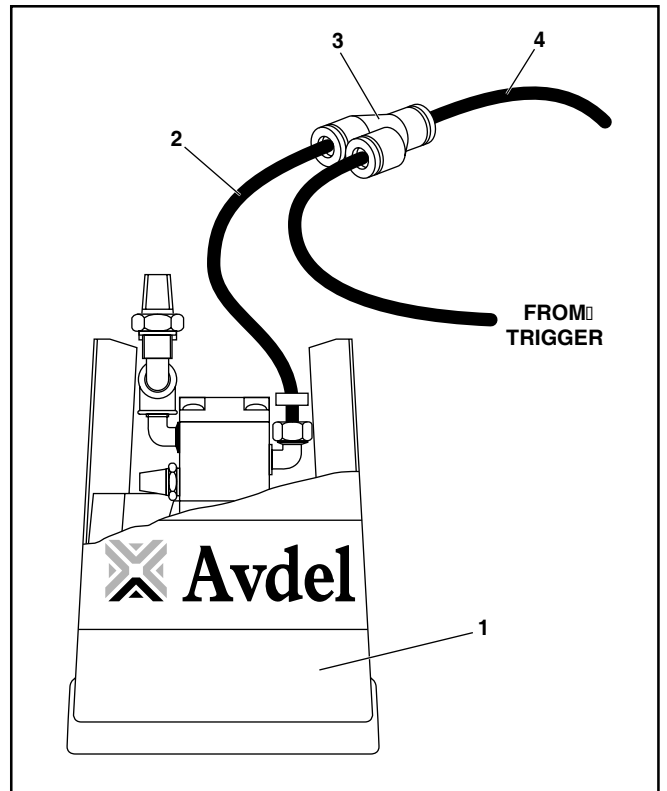

# NOSE ASSEMBLIES

It is essential that the correct nose assembly is fitted prior to operating the tool. By knowing your original complete tool part number or the details of the fastener to be placed, you will be able to order a new complete nose assembly using the selection tables on page 9.

## IMPORTANT

The air supply must be disconnected when fitting or removing nose assemblies unless specifically instructed otherwise.

## FITTING INSTRUCTIONS

- If still fitted remove the nose casing and the adaptor nut.
  - Insert drive shaft 4 into spindle.
  - Fit drive screw 3 onto drive shaft 4.
  - Insert reducing sleeve 5 (if required) into the adaptor nut.
  - Screw the adaptor nut onto the spindle.
  - Hold the spindle with a spanner\* and tighten the adaptor nut clockwise.
  - While holding the adaptor nut with the spanner\*, tighten the lock nut anti-clockwise.
  - Screw on the nose casing and nose tip 1 with the nose tip lock nut.
  - The reverse operation is carried out for equipment removal.
- 
- With tool still disconnected from air supply, screw one insert onto drive screw manually - making sure the insert is flush with the end of drive screw.
  - Set nose tip in exact position and lock nose tip nut clockwise with a spanner\*.
  - Remove the insert from drive screw.

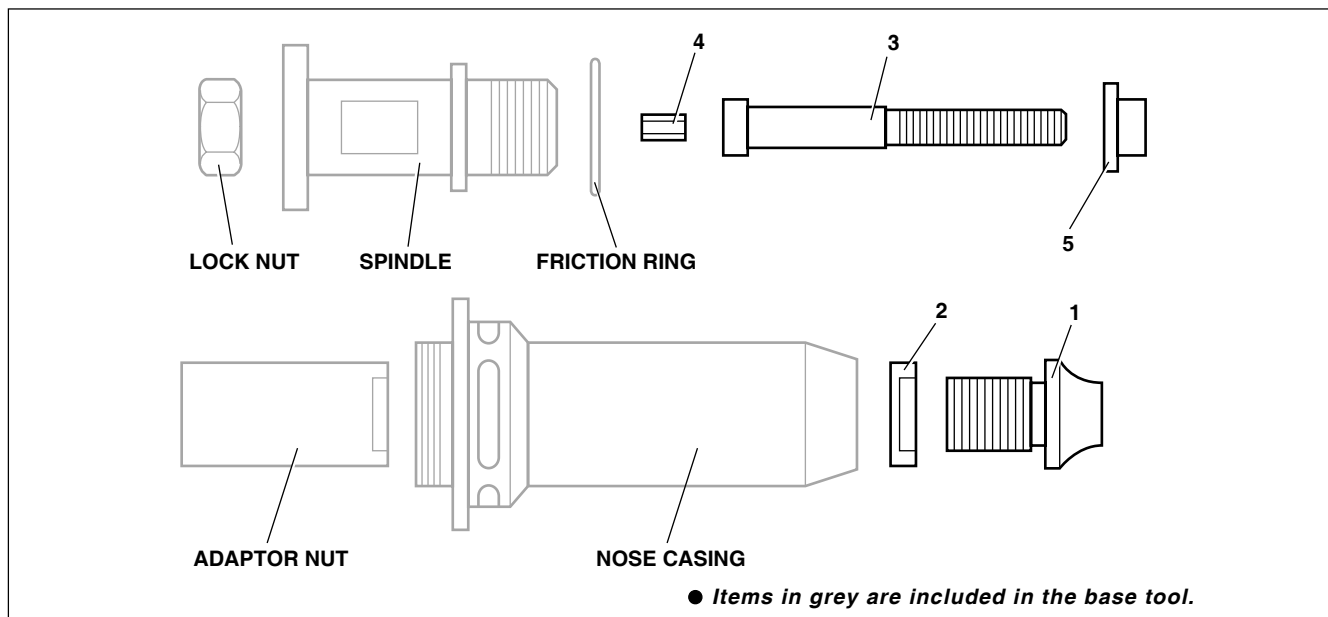

## SERVICING INSTRUCTIONS

Nose assemblies should be serviced at weekly intervals.

- Remove the complete nose assembly using the reverse procedure to the 'Fitting Instructions'.
- Any worn or damaged part should be replaced by a new part.
- Particularly check wear on drive screw.
- Assemble according to fitting instructions.

### ALTERNATIVE ITEMS REQUIRED TO PLACE M12 FASTENERS

ADAPTOR NUT	74401-12028
FRICTION RING	74401-12029
SPINDLE	74401-12030

\* refers to items included in the Avdel service kit. For complete list see page 11.

## NOSE ASSEMBLY COMPONENTS

Nose tips vary in shape according to the insert type. Each nose assembly represents a unique assembly of components which can be ordered individually. All nose assemblies also include a nose tip locknut (part number 07555-00901). Component numbers refer to the illustration on the opposite page. We recommend some stock as items will need regular replacement. Read the Nose Assemblies servicing instructions opposite carefully.

INSERT SIZE	COMPLETE TOOL	NOSE ASSEMBLY	1	3	4	5
<b>LARGE FLANGE INSERTS (9408,9418,GK08,T.S.N.) + STANDARD NUTSERT + SQUARESERT + L.F. HEXSERT (OPEN AND CLOSED END)</b>						
M3	74401-00083	07555-09883	07555-00903	07555-09003	07555-01003	07555-09103
M4	74401-00084	07555-09884	07555-00904	07555-09004	07555-01004	07555-09104
• M5	74401-00485	07555-09185	07555-00915	07555-09005	07555-01005	07555-09105
M5	74401-00085	07555-09885	07555-00905	07555-09005	07555-01005	07555-09105
M6	74401-00086	07555-09886	07555-00906	07555-09006	07555-01006	07555-09106
M8	74401-00088	07555-09888	07555-00908	07555-09008	07555-01008	07555-09108
M10	74401-00080	07555-09880	07555-00910	07555-09010	07555-01010	-
4 UNC	74401-00054	07555-09854	07555-00854	07555-09054	07555-00754	07555-09154
6 UNC	74401-00056	07555-09856	07555-00856	07555-09056	07555-00756	07555-09156
8 UNC	74401-00058	07555-09858	07555-00858	07555-09058	07555-00758	07555-09158
10 UNC	74401-00050	07555-09850	07555-00850	07555-09050	07555-00750	07555-09150
1/4 UNC	74401-00048	07555-09848	07555-00848	07555-09048	07555-00748	07555-09148
5/16 UNC	74401-00040	07555-09840	07555-00840	07555-09040	07555-00740	07555-09140
3/8 UNC	74401-00042	07555-09842	07555-00842	07555-09042	07555-00742	-
10 UNF	74401-00070	07555-09870	07555-00850	07555-09070	07555-00750	07555-09150
1/4 UNF	74401-00068	07555-09868	07555-00848	07555-09068	07555-00748	07555-09148
5/16 UNF	74401-00060	07555-09860	07555-00840	07555-09060	07555-00740	07555-09140
3/8 UNF	74401-00062	07555-09862	07555-00842	07555-09062	07555-00742	-
<b>THIN SHEET NUTSERT ( OPEN AND CLOSED END )</b>						
M3	74401-00183	07555-09983	07555-00993	07555-09003	07555-01003	07555-09103
M4	74401-00184	07555-09984	07555-00994	07555-09004	07555-01004	07555-09104
M5	74401-00185	07555-09985	07555-00995	07555-09005	07555-01005	07555-09105
M6	74401-00186	07555-09986	07555-00996	07555-09006	07555-01006	07555-09106
M8	74401-00188	07555-09988	07555-00998	07555-09008	07555-01008	07555-09108
M10	74401-00180	07555-09980	07555-00999	07555-09010	07555-01010	-
4 UNC	74401-00154	07555-09954	07555-00954	07555-09054	07555-00754	07555-09154
6 UNC	74401-00156	07555-09956	07555-00956	07555-09056	07555-00756	07555-09156
8 UNC	74401-00158	07555-09958	07555-00958	07555-09058	07555-00758	07555-09158
10 UNC	74401-00150	07555-09950	07555-00950	07555-09050	07555-00750	07555-09150
1/4 UNC	74401-00148	07555-09948	07555-00948	07555-09048	07555-00748	07555-09148
5/16 UNC	74401-00140	07555-09940	07555-00940	07555-09040	07555-00740	07555-09140
10 UNF	74401-00170	07555-09970	07555-00950	07555-09070	07555-00750	07555-09150
1/4 UNF	74401-00168	07555-09968	07555-00948	07555-09068	07555-00748	07555-09148
5/16 UNF	74401-00160	07555-09960	07555-00940	07555-09060	07555-00740	07555-09140
<b>SUPERSERT - OPEN AND CLOSED END</b>						
M3	74401-00283	07555-09583	07555-07103	07555-09003	07555-01003	07555-09103
M4	74401-00284	07555-09584	07555-07104	07555-09004	07555-01004	07555-09104
M5	74401-00285	07555-09585	07555-07105	07555-09005	07555-01005	07555-09105
M6	74401-00286	07555-09586	07555-07106	07555-09006	07555-01006	07555-09106
M8	74401-00288	07555-09588	07555-07108	07555-09008	07555-01008	07555-09108
8 UNC	74401-00258	07555-09558	07555-07158	07555-09058	07555-00758	07555-09158
10 UNC	74401-00250	07555-09550	07555-07150	07555-09050	07555-00750	07555-09150
1/4 UNC	74401-00248	07555-09548	07555-07148	07555-09048	07555-00748	07555-09148
8 UNF	74401-00278	07555-09578	07555-07158	07555-09078	07555-00758	07555-09158
10 UNF	74401-00270	07555-09570	07555-07150	07555-09070	07555-00750	07555-09150
1/4 UNF	74401-00268	07555-09568	07555-07148	07555-09068	07555-00748	07555-09148
<b>HEXSERT ( OPEN AND CLOSED END )</b>						
M3	74401-00683	07555-09283	07555-08103	07555-09003	07555-01003	07555-09103
M4	74401-00684	07555-09284	07555-08104	07555-09004	07555-01004	07555-09104
M5	74401-00685	07555-09285	07555-08105	07555-09005	07555-01005	07555-09105
M6	74401-00686	07555-09286	07555-08106	07555-09006	07555-01006	07555-09106
M8	74401-00688	07555-09288	07555-08108	07555-09008	07555-01008	07555-09108
<b>ABOVE M12</b>						
M12	-	-	07555-00912	74401-09012	07555-01012	-
** M12	-	-	07555-00992	74401-09012	07555-01012	-

• Places M5 large flange Thin Sheet Nutsert 09698-00516 ONLY

\*\* Thin Sheet only

# SERVICING THE TOOL

Regular servicing should be carried out and a comprehensive inspection performed annually or every 500000 cycles, whichever is sooner.

## IMPORTANT

**The employer is responsible for ensuring that tool maintenance instructions are given to the appropriate personnel. The operator should not be involved in maintenance or repair of the tool unless properly trained.**

### DAILY

- Daily, before use or when first putting the tool into service, pour a few drops of clean, light lubricating oil into the air inlet of the tool if no lubricator is fitted on air supply. If the tool is in continuous use, the air hose should be disconnected from the main air supply and the tool lubricated every two to three hours.
- Check for air leaks. If damaged, hoses and couplings should be replaced by new items.
- If there is no filter on the pressure regulator, bleed the air line to clear it of accumulated dirt or water before connecting air hose to tool.
- Check that the nose assembly is correct.
- Check the stroke of the tool is adequate to place selected insert. (see stroke adjustment page 5).
- Inspect the drive screw in the nose assembly for wear or damage. If any, renew.

### WEEKLY

- Check for oil leaks and air leaks on air supply hose and fittings.

For all servicing we recommend the use of the service kit, part number 74401-13800, and the combination spanner kit, part number 74401-99993.

SERVICE KIT		
ITEM PART N°	DESCRIPTION	N° OFF
07900-00618	PUSHER	1
07900-00639	NYLON BUSH	1
07900-00640	METAL BUSH	1
07900-00641	BULLET	1

COMBINATION SPANNER KIT		
ITEM PART N°	DESCRIPTION	N° OFF
07900-00409	12mm/13mm SPANNER	1
07900-00632	17mm/19mm SPANNER	2
07900-00426	COMBINATION SPANNER	1
07900-00624	4mm PIN PUNCH	1
74200-12196	17mm THIN SPANNER	1
07900-00642	27mm/30mm SPANNER	1
07900-00224	4mm ALLEN KEY	1

Grease used during tool maintenance can be ordered as a single item, the part number is shown in the service kit above.

MOLY LITHIUM GREASE EP 3753 SAFETY DATA	
<p><b>FIRST AID</b>  <b>SKIN:</b> As the grease is completely water resistant it is best removed with an approved emulsifying skin cleaner.  <b>INGESTION:</b> Make the individual drink 30ml Milk of Magnesia, preferably in a cup of milk.  <b>EYES:</b> Irritant but not harmful. Irrigate with water and seek medical attention.</p> <p><b>ENVIRONMENT</b>            Scrape up for burning or disposal on approved site.</p>	<p><b>FIRE</b>  <b>FLASH POINT:</b> Above 220°C.            Not classified as flammable.            Suitable extinguishing media: CO<sub>2</sub>, Halon or water spray if applied by an experienced operator.</p> <p><b>HANDLING</b>            Use barrier cream or oil resistant gloves</p> <p><b>STORAGE</b>            Away from heat and oxidising agent.</p>

## MAINTENANCE

Every 500000 cycles the tool should be completely dismantled and components replaced where worn, damaged or when recommended. All 'O' rings and seals should be replaced with new ones and lubricated with Moly Lithium grease EP 3753 before assembling.

### IMPORTANT

**Safety Instructions appear on pages 2 & 3.**  
**The employer is responsible for ensuring that tool maintenance instructions are given to the appropriate personnel.**  
**The operator should not be involved in maintenance or repair of the tool unless properly trained.**

The airline must be disconnected before any servicing or dismantling is attempted unless specifically instructed otherwise.

It is recommended that any dismantling operation be carried out in clean conditions.

Item **numbers in bold** refer to the handle assembly drawing and parts list, pages 14 - 15.

Prior to dismantling the tool it is necessary to remove the nose assembly. For simple removal instructions see the nose assemblies section, pages 8 - 9.

Remove bleed screw **32** and washer **31** and drain oil from tool.

For total tool servicing we advise that you proceed with dismantling of sub-assemblies in the order shown below.

To disconnect the oil hose **46** and air delivery and return hoses **45** from the tool, disengage spiral protection sleeve **47** from sleeve **39** and lower sleeve **39** to gain access to the hoses. Disconnect air hoses by pushing and releasing the quick release connectors. Using two spanners, undo oil hose **46** at connector **38** leaving the connector attached to the handle of the tool. Remove the tool.

Remove the nose equipment from the tool by loosening the nose tip locknut and unscrewing the nose tip. Unscrew nose casing **33**, and with the aid of spanners\* remove the components of the nose assembly. Remove the two air tubes **48** from connectors **1**.

## HEAD ASSEMBLY

- Using the pins of the combination spanner\*, unscrew stroke adjustment locknut **12**.
- Withdraw stroke adjustment locknut **12**, air motor casing **3**, spring **13**, movement pivot **22**, shim adjustment ring **23**, piston **24** and lip seal **25**.
- Grip the flats on the air motor casing **3** in a vice fitted with soft jaws and with a spanner\* separate the air motor assembly from the piston **24**. Spring **13** and stroke adjustment locknut **12** can now be removed from air motor casing **3**.
- Using circlip pliers\* remove circlip **26** and extract lip seal **46**.
- From the air motor casing **3** remove centre connector **1** using an Allen key\* and extract spring **2**, ball **4** and pushrod **5**.
- Reassemble in reverse order of dismantling, observing the following:
  - Use nylon bush\* and pusher\* to fit lip seal **46** into its housing.
  - Use circlip pliers\* to fit circlip **26**.
  - Insert metal bush\* into handle **28**.
  - Fit lip seal **25** onto piston **24**.
  - Screw bullet\* onto piston **24** to ease insertion of lip seal **25** into the handle.
  - Insert piston **24** into the handle through the metal bush\*, then remove the bush\* and bullet\* from piston.

\* refers to items included in the Avdel service kit. For complete list see page 10.

## AIR MOTOR ASSEMBLY

- Tap the air motor casing gently on the bench to remove the air motor assembly from the casing.
- Using circlip pliers\*, remove circlip **14**.
- Remove bearing **15** and planet gear spindle **11**, together with three planets **16** from planet gear **10**.
- Remove planet gear **10** and spacer **17**.
- Using a soft mallet, tap on splined head of rotor **19** and remove bearing **9** and front end plate **8**.
- Tap out rotor **19** and rotor blades **7**.
- Place rear end plate **20** in the vice and using a pin punch\*, tap on centre of rotor **19** to remove bearing **21**. Take care not to lose pin **6**.
- Remove bearing **21**.
  
- Assemble in reverse order of dismantling, observing the following:
- Rear side of rotor **19** must just touch rear end plate **20** without any axial gap. Any existing gap will disappear when bearing **21** is fully located.
- When inserting the air motor assembly into air motor casing **3**, align components so that pin **6** locates the centre hole between the spin-on and spin-off ports of the air motor casing.

## HANDLE AND TRIGGER ASSEMBLY

- Using a spanner, undo locknut **35** and remove trigger **34**, 'O' ring **36** and spring **2** from handle **28**.
- Remove screw **45** to release emergency spin-off button **44**.
  
- Assemble in reverse order of dismantling.

## CABINET

- The cabinet comprises an intensifier, a pilot valve, a pressure regulator and filtering unit and an air pressure indicating assembly together with the air hoses internal to the cabinet.
- Servicing is limited to removal/replacement of complete assemblies and the renewal of seals within the pilot valve.
- To dismantle the cabinet it is necessary to extract the base plate and the components installed on it. This is possible after disconnecting all hoses and removing items restricting the withdrawal of the base plate.

## INTENSIFIER

- To remove the intensifier and oil reservoir, disconnect the oil hose **66** (page 18) using two spanners, (be prepared for oil spillage from hose/intensifier), then remove the hose **70** (page 18) (quick release connector) connecting the intensifier to the pilot valve.
- Using a spanner, remove the two nuts **7** and associated washers **6** securing the intensifier to the baseplate **62**.
- Lift intensifier clear of cabinet.
  
- Replacement is in reverse order of removal.

\* refers to items included in the Avdel service kit. For complete list see page 11.

## PILOT VALVE

- Servicing of the valves 27 is limited to the removal/replacement of 'O' rings.
- Remove screws 58 and remove pilot assembly .
- Remove pilot valve 45 and discard 'O' rings 37, 44, 38 and 39.
- Remove screws 55 & 60 and remove end caps 56 & 59.
- Withdraw pistons 52 & 46 and remove 'O' rings 41 & 43 from pistons.
- Withdraw spool 50 from bore, taking care not to damage surface of spool and remove location washers 48 & 51, 'O' ring 42, spacers 49 and 'O' ring 40 from each end of valve body.
- Remove the five interface 'O' rings.
- Discard ALL 'O' rings removed.
  
- Clean all parts with paraffin or white spirit. DO NOT USE SOLVENTS, blow off and dry all parts.
  
- Lightly smear bores of valve body 57, pilot valve body 53, both end caps 59 & 56 and all replacement 'O' rings with "CENTOPLEX 2" grease.
- Fit new seals 44, 38 and 39 to piston 45 and insert into pilot valve body 53.
- Fit new seals 37, 44 and 40 to pilot valve body, place top cap 54 in position and secure pilot valve assembly to the main valve body 57 with screws 58. Ensure that the interface seal housing faces upward with the G1/4 at the bottom. Ensure orientation of pilot valve 45 is correct.
- With main valve body 57 in the same position, fit green location washer 51 to the left hand side of the valve assembly.
- Starting from the right hand side of the valve, assemble alternately the 'O' rings 42 and spacers 49 (6 seals and 5 spacers) and finally complete the stack assembly with white location washer 48.
- Lightly smear spool 50 with "CENTOPLEX 2" grease and slide spool through seal/spacer stack.
- Fit seals 43 & 41 to respective pistons 52 & 46, fit seals 40 to ends of main valve body 57.
- Insert pistons into end caps 56 & 59 and assemble end caps to valve, taking care to locate piston shafts into holes in the ends of the spool 50.
- Secure end cap assemblies to main valve body 57 with screws 55 & 60.
- Fit interface 'O' rings into their housings in the main valve body 57.
- If the pipe connection to the pilot assembly is damaged, replace the plastic collet 36 and lift out the 'O' ring from the cartridge 61.
- Fit new 'O' ring 35 and insert plastic collet 36 into the cartridge.

## PRESSURE REGULATOR AND FILTERING ASSEMBLY

- To remove the assembly from the cabinet, disconnect the two hoses (items 71 and 76 on page 18) at the regulator.
- Remove the two screws, spacers, washers and nuts securing the regulator to the cabinet.
- Remove assembly from the cabinet.
  
- Replacement is in reverse order of removal.

## AIR PRESSURE INDICATOR ASSEMBLY

- To remove the assembly, remove the air hose from the rear of the gauge 55.
- Remove the clamp from the rear of the gauge and withdraw gauge from front of the cabinet.
  
- Replacement is in reverse order of removal.

### IMPORTANT

Check the tool against daily and weekly servicing.  
Priming is ALWAYS necessary after the tool has been dismantled and prior to operating.

\* refers to items included in the Avdel service kit. For complete list see page 11.

GENERAL ASSEMBLY OF HANDLE ASSEMBLY 74401-12000

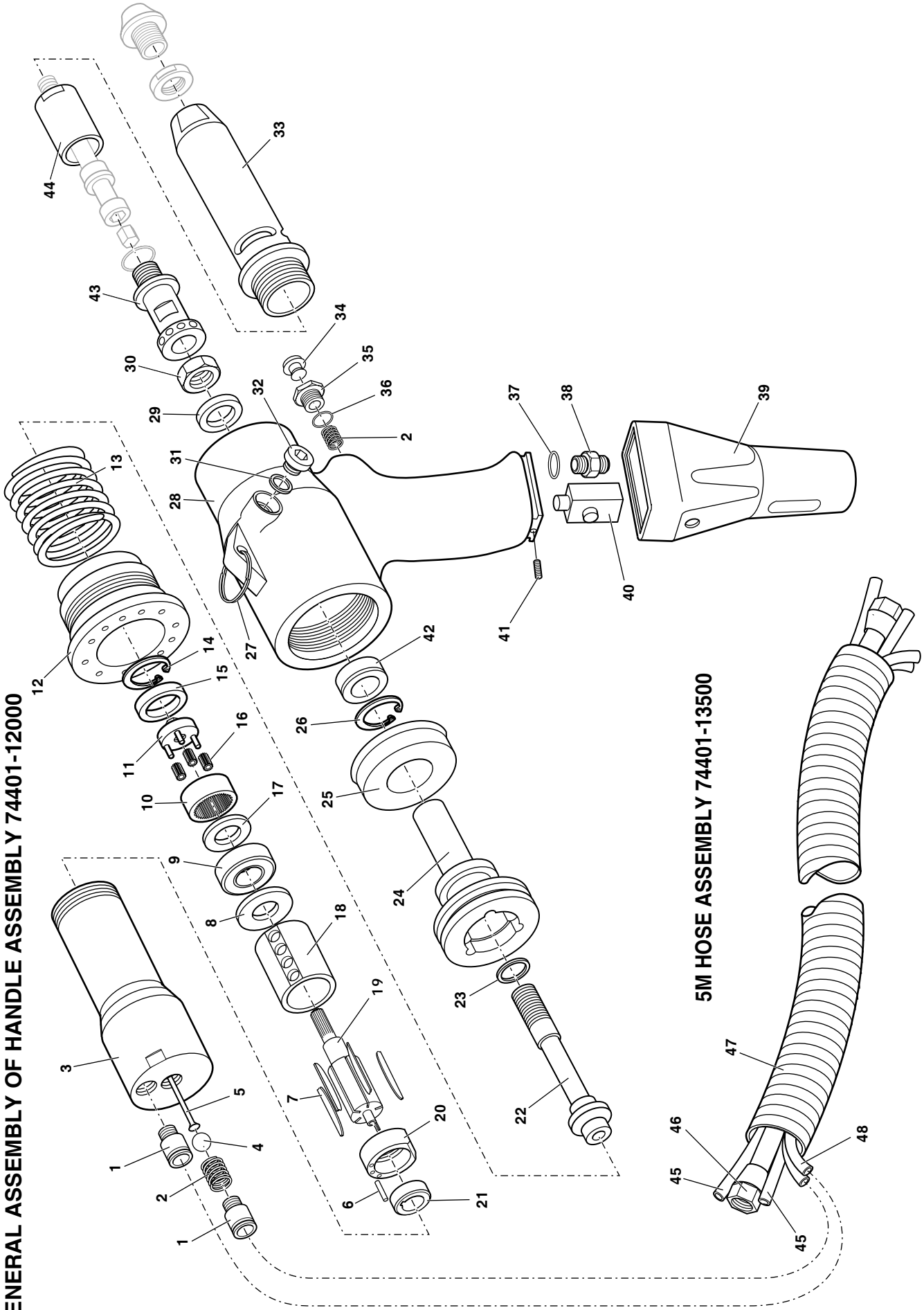

5M HOSE ASSEMBLY 74401-13500

74401-12000 PARTS LIST										
ITEM	PART N <sup>o</sup>	DESCRIPTION	QTY	REC. SPARES	ITEM	PART N <sup>o</sup>	DESCRIPTION	QTY	REC. SPARES	ITEM
1	07655-09220	CONNECTOR	2	-	23	74200-12055	SHIM ADJUSTMENT RING	1	1	
2	07555-09219	SPRING	2	-	24	74401-12020	PISTON	1	-	
3	74401-12046	AIR MOTOR CASING	1	-	25	74401-12021	LIP SEAL	1	-	
4	07555-09218	BALL	1	-	26	07265-02005	CIRCLIP	1	-	
5	74401-12047	PUSH ROD	1	1	27	07265-03021	SUSPENSION RING	1	-	
6	07555-09216	PIN	1	-	28	74401-12001	FORGED HANDLE	1	-	
7	07555-09213	ROTOR BLADE	5	5	29	74401-12054	SPACER	1	-	
8	07555-09210	FRONT END PLATE	1	-	30	07655-00803	LOCKNUT	1	-	
9	07555-09206	BEARING	1	-	31	07265-02011	WASHER	1	-	
10	74200-12065	PLANET GEAR	1	-	32	07265-02010	BLEED SCREW	1	1	
11	74200-12063	PLANET GEAR SPINDLE	1	-	33	74401-12027	NOSE CASING	1	-	
12	74401-12026	STROKE ADJUSTMENT LOCKNUT	1	-	34	07265-03023	TRIGGER	1	-	
13	74401-12025	SPRING	1	-	35	07265-03022	LOCKNUT	1	-	
14	74200-12061	CIRCLIP	1	1	36	07555-00502	'O' RING	1	-	
15	74200-12062	BEARING	1	-	37	07265-02031	WASHER	1	-	
16	07555-09208	PLANET	1	-	38	07265-02032	CONNECTOR	1	-	
17	74200-12066	SPACER	1	-	39	74401-12008	SLEEVE	1	-	
18	07555-09211	STATOR	1	-	40	74401-12003	EMERGENCY SPIN OFF BUTTON	1	-	
19	74200-12070	ROTOR	1	-	41	74401-12002	SCREW	1	-	
20	07555-09214	REAR END PLATE	1	-	42	07265-02004	LIP SEAL	1	1	
21	07555-09215	BEARING	1	-	43	74200-12044	SPINDLE	1	-	
22	74200-12056	MOVEMENT PIVOT	1	-	44	74200-12092	ADAPTOR NUT	1	1	

74401-13500 PARTS LIST										
ITEM	PART N <sup>o</sup>	DESCRIPTION	QTY	REC. SPARES	ITEM	PART N <sup>o</sup>	DESCRIPTION	QTY	REC. SPARES	ITEM
45	07265-02063	AIR DELIVERY AND RETURN HOSE	2	-	47	07267-01502	SPIRAL PROTECTION SLEEVE	1	1	
46	07265-02061	OIL HOSE	1	-	48	74401-12012	AIR HOSE	2	-	

# GENERAL ASSEMBLY OF CABINET 74401-01300

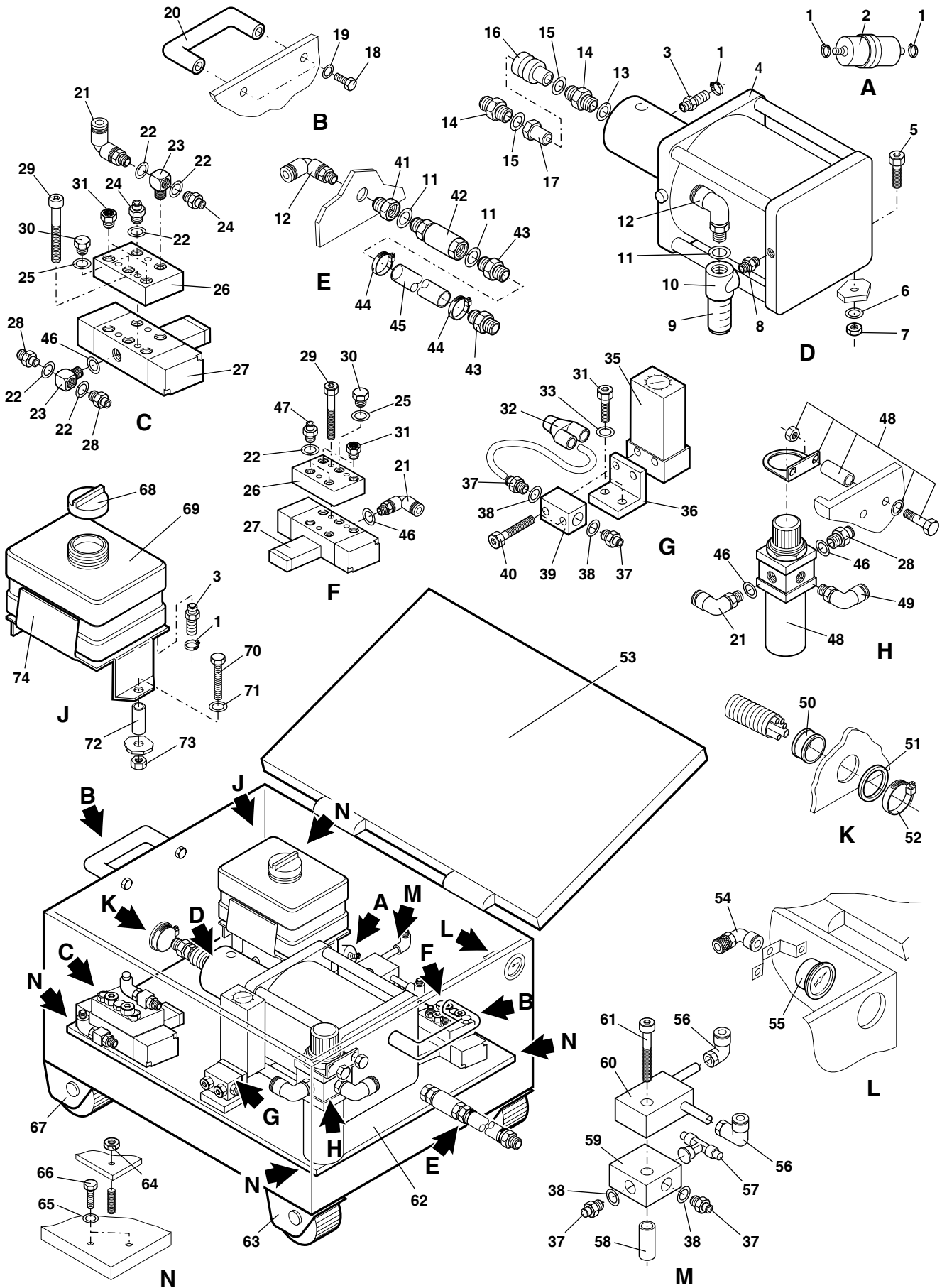

### 74401-01300 CABINET PARTS LIST

ITEM	PART N <sup>o</sup>	DESCRIPTION	QTY	SPARES	ITEM	PART N <sup>o</sup>	DESCRIPTION	QTY	SPARES
1	07267-03211	CLAMP	4	-	46	74401-13080	WASHER	4	-
2	07267-03212	OIL FILTER	1	-	47	74401-13025	STRAIGHT CONNECTOR	2	-
3	07267-03210	HOSE CONNECTOR	2	-	48	07265-03220	PRESSURE REG & FILTER ASSY	1	-
4	07005-01652	INTENSIFIER	1	-	49	07265-03256	ELBOW CONNECTOR	1	-
5	07265-02267	BOLT	2	-	50	07267-03251	RUBBER RING	1	-
6	07625-02268	WASHER	2	-	51	07267-03252	SPACING WASHER	1	-
7	07265-02269	NUT	2	-	52	07265-03292	CLAMP	1	-
8	07265-03260	CONNECTOR	1	-	53	07265-03201	BOX (inc. Key)	1	-
9	07265-03263	SILENCER	1	-	54	07265-03255	ELBOW CONNECTOR	1	-
10	07265-03225	QUICK EXHAUST	1	-	55	07265-03254	AIR PRESSURE INDICATOR	1	-
11	07265-03261	WASHER	3	-	56	74401-13024	ELBOW CONNECTOR	2	-
12	07267-03262	ELBOW CONNECTOR	2	-	57	07265-03904	'T' CONNECTOR	1	-
13	07265-03259	WASHER	1	-	58	74401-13009	SPACER	1	-
14	07265-03258	CONNECTOR	2	-	59	74401-13021	SELECTOR	1	-
15	74401-13037	WASHER	2	-	60	74401-13022	VALVE	1	-
16	07265-02055	QUICK RELEASE CONNECTOR	1	-	61	74401-13020	SCREW	1	-
17	07265-02065	QUICK RELEASE NIPPLE	1	-	62	07265-03230	BASE PLATE	1	-
18	07265-02283	SCREW	4	-	63	07265-03203	FIXED WHEEL	2	-
19	07265-02284	WASHER	4	-	64	74401-13039	NUT	4	-
20	07265-03202	HANDLE	2	-	65	07265-03204	WASHER	8	-
21	74401-13004	ELBOW CONNECTOR	3	-	66	07265-03205	NUT	8	-
22	74401-13078	WASHER	7	-	67	07265-03207	SWIVELLING WHEEL	2	-
23	74401-13023	TWO WAY CONNECTOR	2	-	68	07267-03213	OIL RESERVOIR PLUG	1	-
24	07265-03269	STRAIGHT CONNECTOR	2	-	69	07267-03214	OIL RESERVOIR	1	-
25	07265-03268	WASHER	2	-	70	07267-03216	BOLT	2	-
26	07265-03222	SUB BASE	2	-	71	07267-03218	WASHER	2	-
27	07005-00590	VALVE	2	-	72	07267-03217	SPACER	2	-
28	07265-03271	STRAIGHT CONNECTOR	3	-	73	07267-03219	NUT	2	-
29	07265-03266	SCREW	3	-	74	07267-03215	OIL RESERVOIR BASE	1	-
30	07267-03208	PLUG	2	-	80	74401-13074	4mm AIR HOSE (550mm)	1	-
31	07265-03270	SILENCER	4	-	81	07265-02063	4mm AIR HOSE (5500mm)	2	-
32	74401-13027	'Y' CONNECTOR	1	-	82	74401-13072	4mm AIR HOSE (170mm)	1	-
33	74401-13082	WASHER	2	-	83	74401-12012	6mm AIR HOSE (5500mm)	2	-
34	07265-09507	SCREW	2	-	84	74401-13073	4mm AIR HOSE (250mm)	1	-
35	74401-13075	TIMER	1	-	85	74401-13065	9mm OIL HOSE (150mm)	2	-
36	74401-13076	BRACKET	1	-	86	74401-13093	4mm AIR HOSE (420mm)	1	-
37	74401-13026	STRAIGHT CONNECTOR	4	-	87	74401-13067	10mm AIR HOSE (300mm)	1	-
38	74401-13079	WASHER	4	-	88	07265-03215	10mm AIR HOSE (110mm)	1	-
39	74401-13099	FLOW REGULATOR	1	-	89	74401-13096	4mm AIR HOSE (60mm)	1	-
40	74401-13083	SCREW	2	-	90	74401-13095	4mm AIR HOSE (250mm)	1	-
41	07267-03263	BUSH	1	-	91	74401-13098	4mm AIR HOSE (200mm)	1	-
42	07267-03264	AIR TUBE	1	-	92	74401-13069	10mm AIR HOSE (670mm)	1	-
43	07265-03253	CONNECTOR	2	-	93	74401-13068	10mm AIR HOSE (320mm)	1	-
44	07265-02076	CLAMP	2	-	94	74401-13071	4mm AIR HOSE (260mm)	1	-
45	07265-03219	AIR HOSE (2500 mm)	1	-					

# PNEUMATIC DIAGRAM OF CABINET 74401-01300

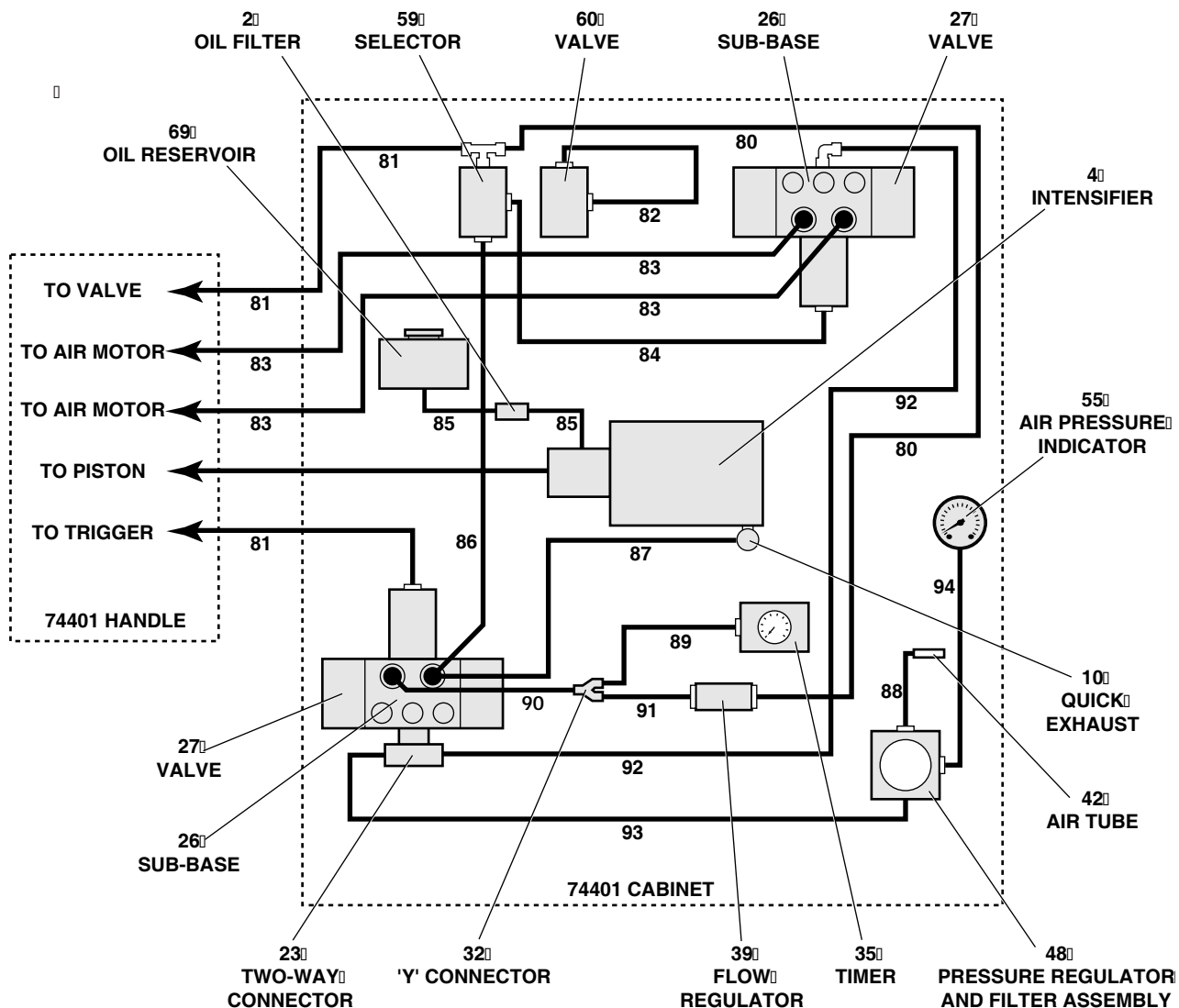

## GENERAL ASSEMBLY OF PULL INTENSIFIER 07005-01652

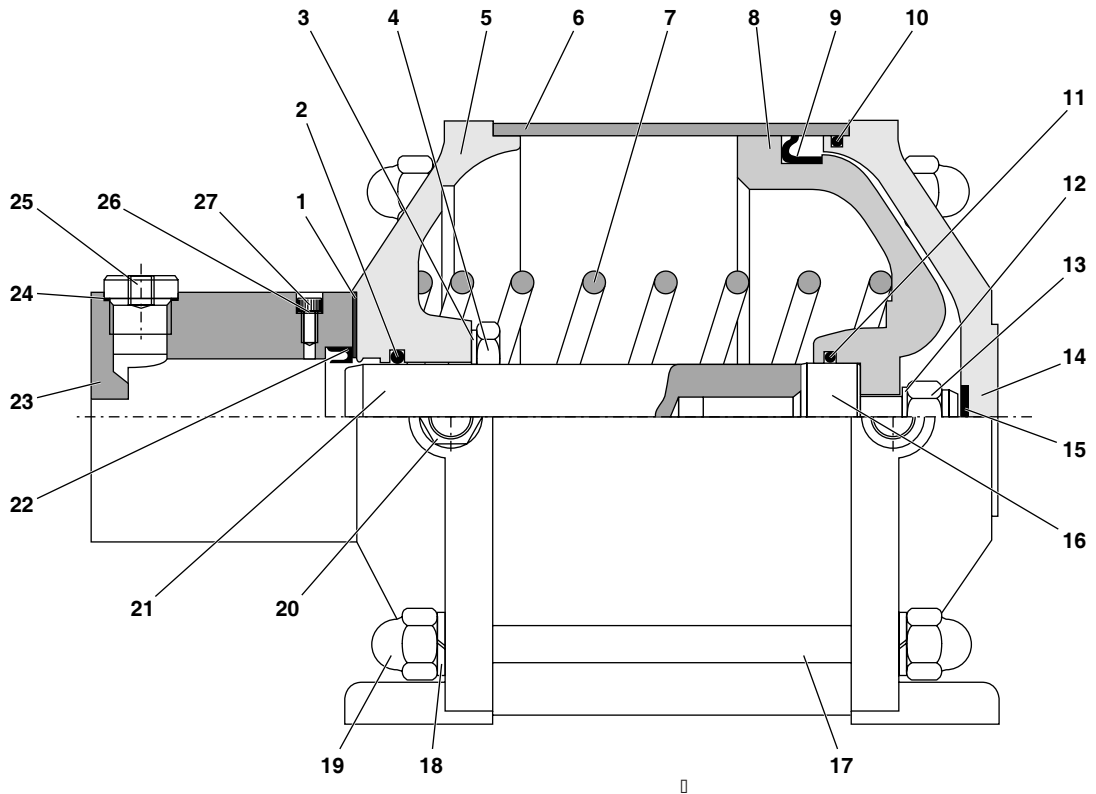

### 07005-01652 PULL INTENSIFIER PARTS LIST

ITEM	PART N <sup>o</sup>	DESCRIPTION	QTY	SPARES	ITEM	PART N <sup>o</sup>	DESCRIPTION	QTY	SPARES
1	07267-08019	SEAL	4	-	15	07267-08035	SHOCK ABSORBER	1	-
2	07267-08004	SEAL	1	-	16	07267-08032	ROD EXTENSION	1	-
3	07267-08022	WASHER	4	-	17	07267-08014	TENSION ROD	4	-
4	07267-08006	SCREW	4	-	18	07267-08026	SPRING WASHER	8	-
5	07627-08007	FRONT FLANGE	1	-	19	07267-08013	BLIND NUT	8	-
6	07267-08017	PNEUMATIC CYLINDER	1	-	20	07267-08033	FILTER	1	-
7	07267-08008	SPRING	1	-	21	07267-08009	ROD	1	-
8	07267-08010	PISTON	1	-	22	07267-08003	SEAL	1	-
9	07267-08011	PISTON SEAL	1	-	23	07267-08002	STEEL HEAD	1	-
10	07267-08012	SEAL	1	-	24	07267-08030	WASHER	1	-
11	07267-08020	SEAL	1	-	25	07267-08029	PLUG	1	-
12	07267-08031	WASHER	1	-	26	07267-08034	WASHER	1	-
13	07267-08015	LOCKNUT	1	-	27	07267-08021	BLEED SCREW	1	-
14	07267-08016	REAR FLANGE	1	-					

# GENERAL ASSEMBLY OF VALVE 07005-00590

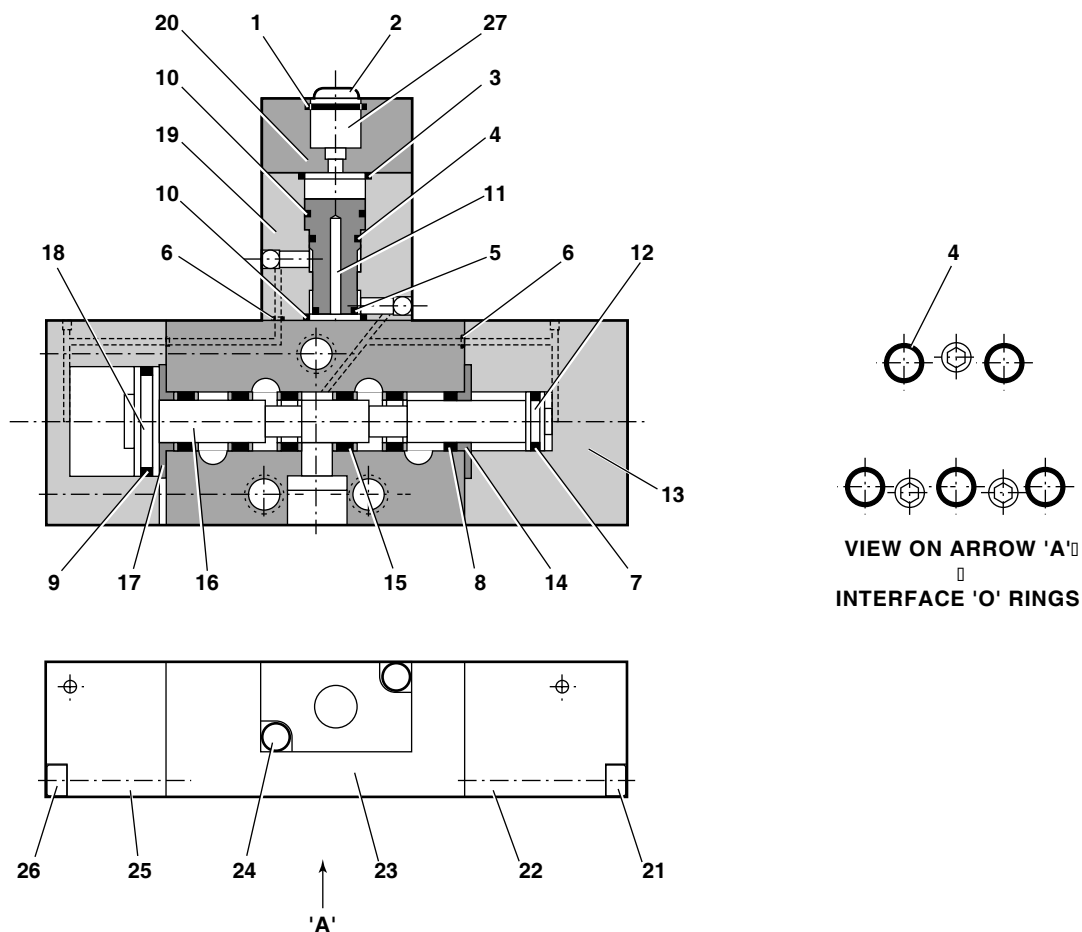

## 07005-00590 VALVE PARTS LIST

ITEM	PART N°	DESCRIPTION	QTY	SPARES	ITEM	PART N°	DESCRIPTION	QTY	SPARES
1	07005-00599	* 'O' RING	-	-	15	-	SPACER	5	-
2	07005-00598	* PLASTIC COLLET	-	-	16	-	SPOOL	1	-
3	07003-00204	* 'O' RING	1	-	17	-	WASHER	1	-
4	07003-00103	* 'O' RING	6	-	18	-	PISTON	1	-
5	07003-00042	* 'O' RING	1	-	19	-	BODY	1	-
6	07003-00121	* 'O' RING	4	-	20	-	TOP CAP	1	-
7	08005-00127	* 'O' RING	1	-	21	-	SCREW	2	-
8	07003-00105	* 'O' RING	6	-	22	-	END CAP	1	-
9	07003-00178	* 'O' RING	1	-	23	-	BODY	1	-
10	07003-00017	* 'O' RING	2	-	24	-	SCREW	2	-
11	-	PISTON	1	-	25	-	END CAP	1	-
12	-	PISTON	1	-	26	-	SCREW	2	-
13	07005-00590	VALVE ASSEMBLY	-	-	27	-	CARTRIDGE	1	-
14	-	WASHER	1	-					

\* SPARES KIT ( PART NO. 07005-01538 )



# PRIMING

Priming is ALWAYS necessary after the tool has been dismantled and prior to operating. It may also be necessary to restore the full stroke after considerable use, when the stroke may be reduced and inserts are not fully placed by one operation of the trigger.

## OIL DETAILS

The recommended oil for priming is Hyspin VG32 available in 0.5l (part number 07992-00002) or one gallon containers (part number 07992-00006). Please find specific table and safety data below.

H Y S P I N V G 3 2 O I L S A F E T Y D A T A				
<b>FIRST AID</b> SKIN: Wash thoroughly with soap and water as soon as possible. Casual contact requires no immediate attention. Short term contact requires no immediate attention. INGESTION: Seek medical attention immediately. DO NOT induce vomiting. EYES: Irrigate immediately with water for several minutes. Although NOT a primary irritant, minor irritation may occur following contact. <b>FIRE</b> Suitable extinguishing media: CO2, dry powder, foam or water fog. DO NOT use water jets.			<b>ENVIRONMENT</b> WASTE DISPOSAL: Through authorised contractor to a licenced site. May be incinerated. Used product may be sent for reclamation. SPILLAGE: Prevent entry into drains, sewers and water courses. Soak up with absorbent material. <b>HANDLING</b> Wear eye protection, impervious gloves (e.g. of PVC) and a plastic apron. Use in well ventilated area. <b>STORAGE</b> No special precautions.	
PROPERTIES	RESULT		PROPERTIES	RESULT
ISO oil type		HL	Foaming tendency/stability	
ISO viscosity grade		32		ml @ 24°C Trace/Nil
Kinematic viscosity				ml @ 93.5°C 20/Nil
	cS @ 40°C	32		ml @ 24°C after test @ 93.5°C Trace/Nil
	@ 100°C	5.3	Air release value minutes to	
Relative density	at 20°C	0.875	0.2% air content @ 50°C	4
Viscosity Index		95	Seal compatability index	10
Pour point	°C	- 30	Water separation time	
Open Flash point	°C	232	in minutes to 40-40-0 @54°C	15
Neutralisation value mg KOH/g		1.5	@83°C	15

## PROCEDURE

Item numbers in bold refer to the general assembly and parts list pages 14.

### IMPORTANT

All operations should be carried out on a clean bench, with clean hands in a clean area.  
 Ensure that the oil is perfectly clean and free from air bubbles.  
 Care MUST be taken at all times, to ensure that no foreign matter enters the tool, or serious damage may result.  
 The tool must remain on its side throughout the priming sequence.

- Prior to starting the priming procedure, obtain a suitable container to collect excess oil.
- Disconnect the air supply and undo the intensifier oil reservoir cap.
- Top up the reservoir with VG32 Castrol Hyspin priming oil to a level of 20mm (0.8") below top of reservoir.
- Remove bleed screw **32** and associated washer **31** from placing tool.
- Connect the tool to the air supply.
- Place tool handle over the container with bleed hole orientated towards container and depress the trigger.
- When oil is ejected from bleed hole, release trigger.
- Depress trigger again, replace bleed screw **32** and washer **31** BEFORE releasing trigger again.
- Ensure oil Bleed Screw **32** is fully tightened, then unscrew by ONE TURN only
- Repeat the trigger depressing/releasing sequence, allowing a few seconds between cycles to allow priming oil to circulate.
- Continue until oil flowing from around the bleed screw is free of air bubbles, (ensure that the reservoir is not starved of oil, otherwise air will be drawn into the system introducing air bubbles in the oil stream).
- When oil is flowing and no air bubbles are visible, tighten the bleed screw with an Allen key and release trigger.
- If necessary, top up the oil reservoir.

Item numbers in bold refer to the handle assembly and parts list pages 14 and 15.

SYMPTOM	POSSIBLE CAUSE	REMEDY
Pneumatic motor runs slowly	→ Air leak from motor	→ Check for worn seals. Replace
	→ Low air pressure	→ Increase
	→ Air way blockage	→ Clear restriction in air supply
	→ Worn drive screw	→ Replace
	→ Rotor blades jamming	→ Lubricate tool through air inlet
Insert does not deform properly	→ Stroke incorrectly set	→ Adjust
	→ Air pressure outside the tolerance	→ Adjust
	→ Low oil level	→ Prime tool
	→ Insert out of grip	→ Check grip range of Insert
Drivescrew turns independent of motor	→ Worn or damaged drive shaft	→ Replace
	→ Worn or damaged drive screw	→ Replace
	→ Adaptor nut loose	→ Tighten
Insert will not place onto drivescrew	→ Incorrect Insert thread size	→ Change to correct insert
	→ Incorrect drive screw fitted	→ Change to correct drive screw
	→ Worn or damaged drive screw	→ Replace
	→ Nose equipment incorrectly assembled	→ Disconnect air supply, re-fit nose equipment carefully
Tool is jammed on placed insert	→ Excessive stroke/ Defective Insert/ Worn or defective drive screw	→ DO NOT DEPRESS TRIGGER. Depress emergency spin-off button. Tool should spin off. Reset stroke. If not, disconnect air to tool. Insert a 4 mm Ø pin through nose casing slots into spindle <b>43</b> . Turn until drive screw leaves Insert. Use new insert AND drive screw.
Drive screw breaks	→ Stroke of tool excessive	→ Reset stroke
	→ Side load on drive screw	→ Hold tool square to application when placing Insert
Tool does not spin on	→ Screw adaptor nut loose	→ Tighten
	→ No air supply	→ Connect
	→ Insufficient gap between locknut <b>30</b> and spindle <b>43</b>	→ Adjust to 1.5 mm gap to 2mm gap
	→ Push rod <b>5</b> too short	→ Replace
	→ Air motor jammed	→ Lubricate tool at air inlet. If insufficient dismantle & clean air motor thoroughly
Trigger inoperative	→ Static friction	→ Depress trigger a few times
	→ Low air pressure	→ Increase air pressure
Drivescrew does not return and/or keeps spinning off	→ Lip seal <b>25</b> is defective	→ Replace
Tool does not spin off	→ Adaptor nut <b>44</b> loose	→ Tighten
	→ No air supply	→ Connect
	→ Air motor jammed	→ Lubricate tool at air inlet. If insufficient dismantle & clean air motor thoroughly



**Declaration of Conformity**

We, *Avdel UK Limited, Watchmead Industrial Estate, Welwyn Garden City, Herts, AL7 1LY*  
*Avdel SRL, Via Manin 350-21, 20099 Sesto Giovanni, Milan, Italy*

declare under our sole responsibility that the product

*type 74401*

*Serial N°*

to which this declaration relates is in conformity with the following standards or other formative documents

EN292 part 1 and part 2

ISO 8662 part 1 & 7

ISO 3744 and PNEUROP test code PN8NTC1

ISO PREN792 part 6 & 14

following the provisions of the Machine Directive 98/37/EC

*Delle Fore Michele*

Milan - date of issue

M. Dellefave - Quality Manager

# Holding your world together<sup>®</sup>

---

Find your closest STANLEY Engineered Fastening location on [www.StanleyEngineeredFastening.com/contact](http://www.StanleyEngineeredFastening.com/contact)



For an authorized distributor nearby please check [www.StanleyEngineeredFastening.com/econtact/distributors](http://www.StanleyEngineeredFastening.com/econtact/distributors)

Manual Number	Issue	C/N
07900-00661	B4	14/220

**STANLEY**  
Engineered Fastening

[www.StanleyEngineeredFastening.com](http://www.StanleyEngineeredFastening.com)

© 2013 Stanley Black & Decker, Inc., Rev. 01.2014

Avbolt<sup>®</sup>, Avdel<sup>®</sup>, Avdelok<sup>®</sup>, Avex<sup>®</sup>, Avinox<sup>®</sup>, Avseal<sup>®</sup>, Avtainer<sup>®</sup>, Hemlok<sup>®</sup>, Maxlok<sup>®</sup> and Monobolt<sup>®</sup> are trademarks of Avdel UK Limited. The names and logos of other companies mentioned herein may be trademarks of their respective owners. Data shown is subject to change without prior notice as a result of continuous product development and improvement policy. Your local Avdel representative is at your disposal should you need to confirm latest information.

Avdel UK Limited  
Pacific House, 2 Swiftfields  
Welwyn Garden City, Hertfordshire AL7 1LY  
Tel. +44 (0)1707 292-000 · Fax -199  
[enquiries2@sbdinc.com](mailto:enquiries2@sbdinc.com)